

**INTERNATIONAL
STANDARD**

**ISO
12131-1**

First edition
2001-04-15

**Plain bearings — Hydrodynamic plain
thrust pad bearings under steady-state
conditions**

**Part 1:
Calculation of thrust pad bearings**

*Paliers lisses — Paliers de butées hydrodynamiques à patins géométrie
fixe fonctionnant en régime stationnaire*

Partie 1: Calcul des butées à segments



Reference number
ISO 12131-1:2001(E)

© ISO 2001

ISO 12131-1:2001(E)**PDF disclaimer**

This PDF file may contain embedded typefaces. In accordance with Adobe's licensing policy, this file may be printed or viewed but shall not be edited unless the typefaces which are embedded are licensed to and installed on the computer performing the editing. In downloading this file, parties accept therein the responsibility of not infringing Adobe's licensing policy. The ISO Central Secretariat accepts no liability in this area.

Adobe is a trademark of Adobe Systems Incorporated.

Details of the software products used to create this PDF file can be found in the General Info relative to the file; the PDF-creation parameters were optimized for printing. Every care has been taken to ensure that the file is suitable for use by ISO member bodies. In the unlikely event that a problem relating to it is found, please inform the Central Secretariat at the address given below.

© ISO 2001

All rights reserved. Unless otherwise specified, no part of this publication may be reproduced or utilized in any form or by any means, electronic or mechanical, including photocopying and microfilm, without permission in writing from either ISO at the address below or ISO's member body in the country of the requester.

ISO copyright office
Case postale 56 • CH-1211 Geneva 20
Tel. + 41 22 749 01 11
Fax + 41 22 749 09 47
E-mail copyright@iso.ch
Web www.iso.ch

Printed in Switzerland

Contents

	Page
Foreword.....	iv
1 Scope	1
2 Normative references	1
3 Fundamentals, assumptions and premises	1
4 Symbols and units	3
5 Calculation procedure	6
5.1 Loading operations.....	6
5.2 Load carrying capacity.....	8
5.3 Frictional power	8
5.4 Lubricant flow rate	9
5.5 Heat balance	10
5.6 Minimum lubricant film thickness and specific bearing load	13
5.7 Operating conditions	13
5.8 Further influence factors	13
Annex A (normative) Examples of calculation.....	15
Bibliography	25

ISO 12131-1:2001(E)

Foreword

ISO (the International Organization for Standardization) is a worldwide federation of national standards bodies (ISO member bodies). The work of preparing International Standards is normally carried out through ISO technical committees. Each member body interested in a subject for which a technical committee has been established has the right to be represented on that committee. International organizations, governmental and non-governmental, in liaison with ISO, also take part in the work. ISO collaborates closely with the International Electrotechnical Commission (IEC) on all matters of electrotechnical standardization.

International Standards are drafted in accordance with the rules given in the ISO/IEC Directives, Part 3.

Draft International Standards adopted by the technical committees are circulated to the member bodies for voting. Publication as an International Standard requires approval by at least 75 % of the member bodies casting a vote.

Attention is drawn to the possibility that some of the elements of this part of ISO 12131 may be the subject of patent rights. ISO shall not be held responsible for identifying any or all such patent rights.

International Standard ISO 12131-1 was prepared by Technical Committee ISO/TC 123, *Plain bearings*, Subcommittee SC 4, *Methods of calculation of plain bearings*.

ISO 12131 consists of the following parts, under the general title *Plain bearings — Hydrodynamic plain thrust pad bearings under steady-state conditions*:

- *Part 1: Calculation of thrust pad bearings*
- *Part 2: Functions for the calculation of thrust pad bearings*
- *Part 3: Guide values for the calculation of thrust pad bearings*

Annex A forms a normative part of this part of ISO 12131.

Plain bearings — Hydrodynamic plain thrust pad bearings under steady-state conditions

Part 1: Calculation of thrust pad bearings

1 Scope

The aim of this part of ISO 12131 is to achieve designs of plain bearings that are reliable in operation, by the application of a calculation method for oil-lubricated hydrodynamic plain bearings with complete separation of the thrust collar and plain bearing surfaces by a film of lubricant [1].

This part of ISO 12131 applies to plain thrust bearings with incorporated wedge and supporting surfaces having any ratio of wedge surface length l_{wed} to length of one pad L . It deals with the value $l_{\text{wed}}/L = 0,75$ as this value represents the optimum ratio [2]. The ratio of width to length of one pad can be varied in the range $B/L = 0,5$ to 2.

The calculation method described in this part of ISO 12131 can be used for other incorporated gap shapes, e.g. plain thrust bearings with integrated baffle, when for these types the numerical solutions of Reynolds' differential equation are known.

The calculation method serves for designing and optimizing plain thrust bearings e.g. for fans, gear units, pumps, turbines, electrical machines, compressors and machine tools. It is limited to steady-state conditions, i.e. load and angular speed of all rotating parts are constant under continuous operating conditions. Dynamic operating conditions are not included.

2 Normative references

The following normative documents contain provisions which, through reference in this text, constitute provisions of this part of ISO 12131. For dated references, subsequent amendments to, or revisions of, any of these publications do not apply. However, parties to agreements based on this part of ISO 12131 are encouraged to investigate the possibility of applying the most recent editions of the normative documents indicated below. For undated references, the latest edition of the normative document referred to applies. Members of ISO and IEC maintain registers of currently valid International Standards.

ISO 3448:1992, *Industrial liquid lubricants — ISO viscosity classification*

ISO 12131-2:2001, *Plain bearings — Hydrodynamic plain thrust pad bearings under steady-state conditions — Part 2: Functions for the calculation of thrust pad bearings*

ISO 12131-3, *Plain bearings — Hydrodynamic plain thrust pad bearings under steady-state conditions — Part 3: Guide values for the calculation of thrust pad bearings*

3 Fundamentals, assumptions and premises

The calculation is always carried out with the numerical solutions of Reynolds' differential equation for sliding surfaces with finite width, taking into account the physically correct boundary conditions for the generation of pressure.

ISO 12131-1:2001(E)

$$\frac{\partial}{\partial x} \left(h^3 \frac{\partial p}{\partial x} \right) + \frac{\partial}{\partial z} \left(h^3 \frac{\partial p}{\partial z} \right) = 6 \times \eta \times U \times \frac{\partial h}{\partial x} \quad (1)$$

See [1] for the derivation of Reynolds' differential equation and [2] for the numerical solution.

For the solution of equation (1), the following idealizing assumptions and premises are used, the reliability of which has been sufficiently confirmed by experiment and in practice [3].

- a) The lubricant corresponds to a Newtonian fluid.
- b) All lubricant flows are laminar.
- c) The lubricant adheres completely to the sliding surfaces.
- d) The lubricant is incompressible.
- e) The lubrication clearance gap is completely filled with lubricant.
- f) Inertia effects and gravitational and magnetic forces of the lubricant are negligible.
- g) The components forming the lubrication clearance gap are rigid or their deformation is negligible; their surfaces are completely even.
- h) The lubricant film thickness in the radial direction (z -coordinate) is constant.
- i) Fluctuations in pressure within the lubricant film normal to the sliding surfaces (y -coordinate) are negligible.
- j) There is no motion normal to the sliding surfaces (y -coordinate).
- k) The lubricant is isoviscous over the entire lubrication clearance gap.
- l) The lubricant is fed in at the widest lubrication clearance gap; the magnitude of the lubricant feed pressure is negligible as compared to the lubricant film pressures themselves.
- m) The pad shape of the sliding surfaces is replaced by rectangles.

The boundary conditions for the solution of Reynolds' differential equation are the following.

- 1) The gauge pressure of the lubricant at the feeding point is $p(x = 0, z) = 0$.
- 2) The feeding of the lubricant is arranged in such a way that it does not interfere with the generation of pressure in the lubrication clearance gap.
- 3) The gauge pressure of the lubricant at the lateral edges of the plain bearing is $p(x, z = 0,5 B) = 0$.
- 4) The gauge pressure of the lubricant is $p(x = L, z) = 0$ at the end of the pressure field.

The application of the principle of similarity in hydrodynamic plain bearing theory results in dimensionless parameters of similarity for such characteristics as load carrying capacity, friction behaviour and lubricant flow rate.

The use of parameters of similarity reduces the number of necessary numerical solutions of Reynolds' differential equation which are compiled in ISO 12131-2. In principle, other solutions are also permitted provided they satisfy the conditions given in this part of ISO 12131 and have the corresponding numerical accuracy.

ISO 12131-3, contains guide values according to which the calculation result is to be oriented in order to ensure the functioning of the plain bearings.

In special cases, guide values deviating from ISO 12131-3, may be agreed for specific applications.

4 Symbols and units

See Table 1 and Figure 1.

Table 1 — Symbols and units

Symbol	Designation	Unit
A	Heat emitting surface of the bearing housing	m^2
B	Width of one pad	m
c_p	Specific heat capacity of the lubricant ($p = \text{constant}$)	$J/(kg \cdot K)$
C_{wed}	Wedge depth	m
D	Mean sliding diameter (diameter of thrust bearing ring)	m
D_i	Inside diameter of thrust bearing ring	m
D_o	Outside diameter of thrust bearing ring	m
f^*	Characteristic value of friction	1
f_B^*	Characteristic value of friction for thrust pad bearing	1
F	Bearing force (nominal load)	N
F^*	Characteristic value of load carrying capacity	1
F_B^*	Characteristic value of load carrying capacity for thrust pad bearing	1
F_{st}	Bearing force (load) under stationary conditions	N
h	Local lubricant film thickness (clearance gap height)	m
h_{lim}	Minimum permissible lubricant film thickness during operation	m
$h_{lim, tr}$	Minimum permissible lubricant film thickness in the transition into mixed lubrication	m
h_{min}	Minimum lubricant film thickness (minimum clearance gap height)	m
k	Heat transfer coefficient related to the product $B \times L \times Z$	$W/(m^2 \cdot K)$
k_A	External heat transfer coefficient (reference surface A)	$W/(m^2 \cdot K)$
l_{wed}	Wedge length	m
L	Length of one pad in circumferential direction	m
M	Mixing factor	1
N	Rotational frequency (speed) of thrust collar	s^{-1}
p	Local lubricant film pressure	Pa
\bar{p}	Specific bearing load $\bar{p} = F/(B \times L \times Z)$	Pa
P_f	Frictional power in the bearing or heat flow rate generated by it	W
\bar{p}_{lim}	Maximum permissible specific bearing load	Pa
$P_{th, amb}$	Heat flow rate to the environment	W
$P_{th, L}$	Heat flow rate in the lubricant	W
Q	Lubricant flow rate	m^3/s
Q^*	Characteristic value of lubricant flow rate	m^3/s
Q_0	Relative lubricant flow rate $Q_0 = B \times h_{min} \times U \times Z$	m^3/s
Q_1	Lubricant flow rate at the inlet of the clearance gap (circumferential direction)	m^3/s
Q_1^*	Characteristic value of lubricant flow rate at the inlet of the clearance gap	1

ISO 12131-1:2001(E)

Table 1 — (continued)

Symbol	Designation	Unit
Q_2	Lubricant flow rate at the outlet of the clearance gap (circumferential direction)	m ³ /s
Q^*_2	Characteristic value of lubricant flow rate $Q^*_1 - Q^*_3$ at the outlet of the clearance gap	1
Q_3	Lubricant flow rate at the sides (perpendicular to circumferential direction)	m ³ /s
Q^*_3	Characteristic value of lubricant flow rate at the sides	1
Re	Reynolds number	1
Rz	Average peak-to-valley roughness height of thrust collar	µm
T_{amb}	Ambient temperature	°C
T_B	Bearing temperature	°C
T_{eff}	Effective lubricant film temperature	°C
T_{en}	Lubricant temperature at the inlet of the bearing	°C
T_{ex}	Lubricant temperature at the outlet of the bearing	°C
T_{lim}	Maximum permissible bearing temperature	°C
T_1	Lubricant temperature at the inlet of the clearance gap	°C
T_2	Lubricant temperature at the outlet of the clearance gap	°C
U	Sliding velocity relative to mean diameter of bearing ring	m/s
w_{amb}	Velocity of air surrounding the bearing housing	m/s
x	Coordinate in direction of motion (circumferential direction)	m
y	Coordinate in direction of lubrication clearance gap (axial)	m
z	Coordinate perpendicular to the direction of motion (radial)	m
Z	Number of pads	1
η	Dynamic viscosity of the lubricant	Pa·s
η_{eff}	Effective dynamic viscosity of the lubricant	Pa·s
ρ	Density of the lubricant	kg/m ³

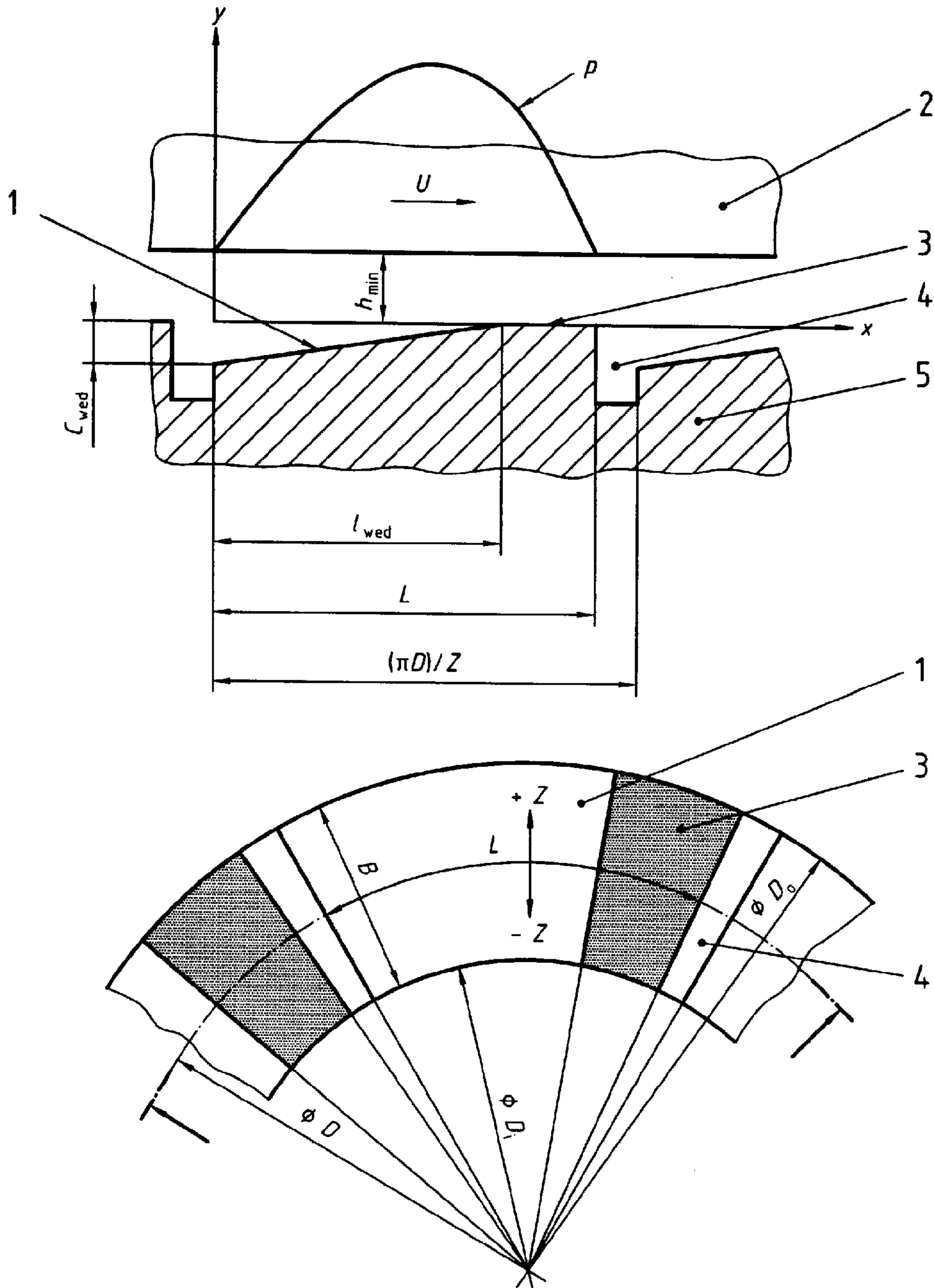

- Key**
- 1 Wedge surface
 - 2 Thrust collar
 - 3 Supporting surface
 - 4 Lubrication groove
 - 5 Thrust bearing ring

Figure 1 — Schematic view of a thrust pad bearing (bearing with incorporated wedge and supporting surfaces)

ISO 12131-1:2001(E)

5 Calculation procedure

5.1 Loading operations

5.1.1 General

Calculation means the mathematical determination of the correct functioning using operational parameters (see Figure 2) which can be compared with guide values. Thereby, the operational parameters determined under varying operation conditions shall be permissible as compared to the guide values. For this purpose, all continuous operating conditions shall be investigated.

5.1.2 Wear

Safety against wear is given if complete separation of the mating bearing parts is achieved by the lubricant. Continuous operation in the mixed lubrication range results in premature loss of functioning. Short-time operation in the mixed lubrication range such as starting up and running down machines with plain bearings, is unavoidable and can result in bearing damage after frequent occurrence. When subjected to heavy load, an auxiliary hydrostatic arrangement may be necessary for starting up or running down at a low speed. Running-in and adaptive wear to compensate for surface geometry deviations from the ideal geometry are permissible as long as these are limited in time and locality and occur without overload effects. In certain cases, a specific running-in procedure may be beneficial. This can also be influenced by the selection of the material. Attention is drawn to the fact that in the case of this bearing design, wear can lead to a rapid decrease in the load carrying capacity.

5.1.3 Mechanical loading

The limits of mechanical loading are given by the strength of the bearing material. Slight permanent deformation is permissible as long as it does not impair correct functioning of the plain bearing.

5.1.4 Thermal loading

The limits of thermal loading result not only from the thermal stability of the bearing material but also from the viscosity-temperature relationship and the ageing tendency of the lubricant.

5.1.5 Outside influences

Calculation of correct functioning of plain bearings presupposes that the operating conditions are known for all cases of continuous operation. In practice, however, additional disturbing influences frequently occur which are unknown at the design stage and cannot always be computed. Therefore, the application of an appropriate safety margin between the operational parameters and the permissible guide values is recommended. Disturbing influences are, e.g.:

- spurious forces (out-of-balance, vibrations, etc.);
- deviations from the ideal geometry (machining tolerances, deviations during assembly, etc.);
- lubricants contaminated by solid, liquid and gaseous foreign matters;
- corrosion, electric erosion, etc.

Information as to further influence factors is given in 5.8.

The applicability of this part of ISO 12131 for which laminar flow in the lubrication clearance gap is a necessary condition, is to be checked by the Reynolds' number:

$$Re = \frac{\rho \times U \times h_{\min}}{\eta_{\text{eff}}} \leq Re_{\text{cr}} \quad (2)$$

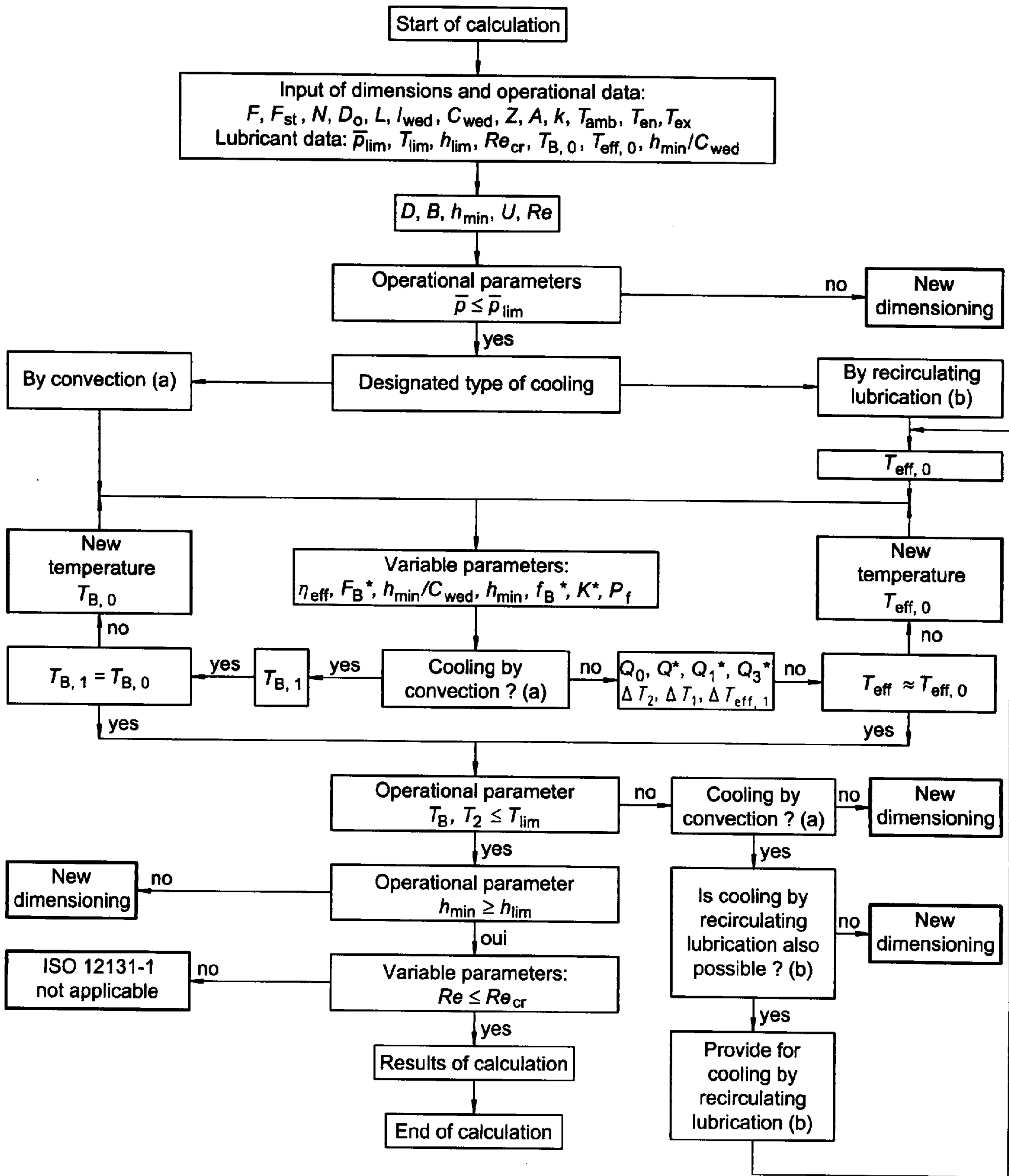

Figure 2 — Scheme of calculation (flow chart)

ISO 12131-1:2001(E)

For wedge-shaped gaps with $h_{\min}/C_{\text{wed}} = 0,8$ a critical Reynolds' number of $Re_{\text{cr}} = 600$ can be assumed as guide value according to [4].

Starting from the known bearing dimensions and operating data the plain bearing calculation comprises:

- the relationship between load carrying capacity and lubricant film thickness;
- the frictional power;
- the lubricant flow rate;
- the heat balance.

These shall be interdependent. The solution is obtained using an iterative method, the sequence of which is summarized in the calculation flow chart in Figure 2.

For optimization of individual parameters, parameter variation can be performed; modification of the calculation sequence is possible.

5.2 Load carrying capacity

The parameter for the load carrying capacity is the dimensionless characteristic value of load carrying capacity F^* :

$$F^* = \frac{F \times h_{\min}^2}{U \times \eta_{\text{eff}} \times L^2 \times B \times Z} \quad (3)$$

Firstly, the minimum lubricant film thickness h_{\min} as well as the effective viscosity η_{eff} are still unknown in equation (3). In order to avoid a double iteration via the minimum lubricant film thickness h_{\min} and the effective bearing temperature T_{eff} , the characteristic value of load carrying capacity F^* according to [5] is modified as follows to be the characteristic value of load carrying capacity for the calculation of thrust pad bearings:

$$F_{\text{B}}^* = F^* \times \left(\frac{C_{\text{wed}}}{h_{\min}} \right)^2 \quad (4)$$

The function $F_{\text{B}} = f(h_{\min}/C_{\text{wed}}; B/L)$ is explained in ISO 12131-2 on the basis of the findings in [6]. Approximate functions are also given there.

5.3 Frictional power

The losses due to friction in a hydrodynamic plain thrust bearing are given by the characteristic value of friction f^* which is defined as follows:

$$f^* = P_{\text{f}} \times \frac{h_{\min}}{U^2 \times \eta_{\text{eff}} \times B \times L \times Z} \quad (5)$$

The characteristic value of friction f^* is also modified as follows to be the characteristic value of friction for thrust pad bearings f_{B}^* according to [5]:

$$f_{\text{B}}^* = f^* \times \frac{C_{\text{wed}}}{h_{\min}} \quad (6)$$

Thus the frictional power is calculated as follows:

$$P_f = f_B^* \times \frac{U^2 \times \eta_{\text{eff}} \times B \times L \times Z}{C_{\text{wed}}} \quad (7)$$

The characteristic value of friction for thrust pad bearings f_B^* can be taken from ISO 12131-2 as a function of the film thickness ratio $h_{\text{min}}/C_{\text{wed}}$ and of the ratio B/L and with this, the frictional power loss P_f can be calculated.

5.4 Lubricant flow rate

The lubricant fed to the bearing forms a solid lubricant film separating the sliding surfaces. At the same time, the lubricant has the task to dissipate the frictional heat developing in the bearing. See Figure 3.

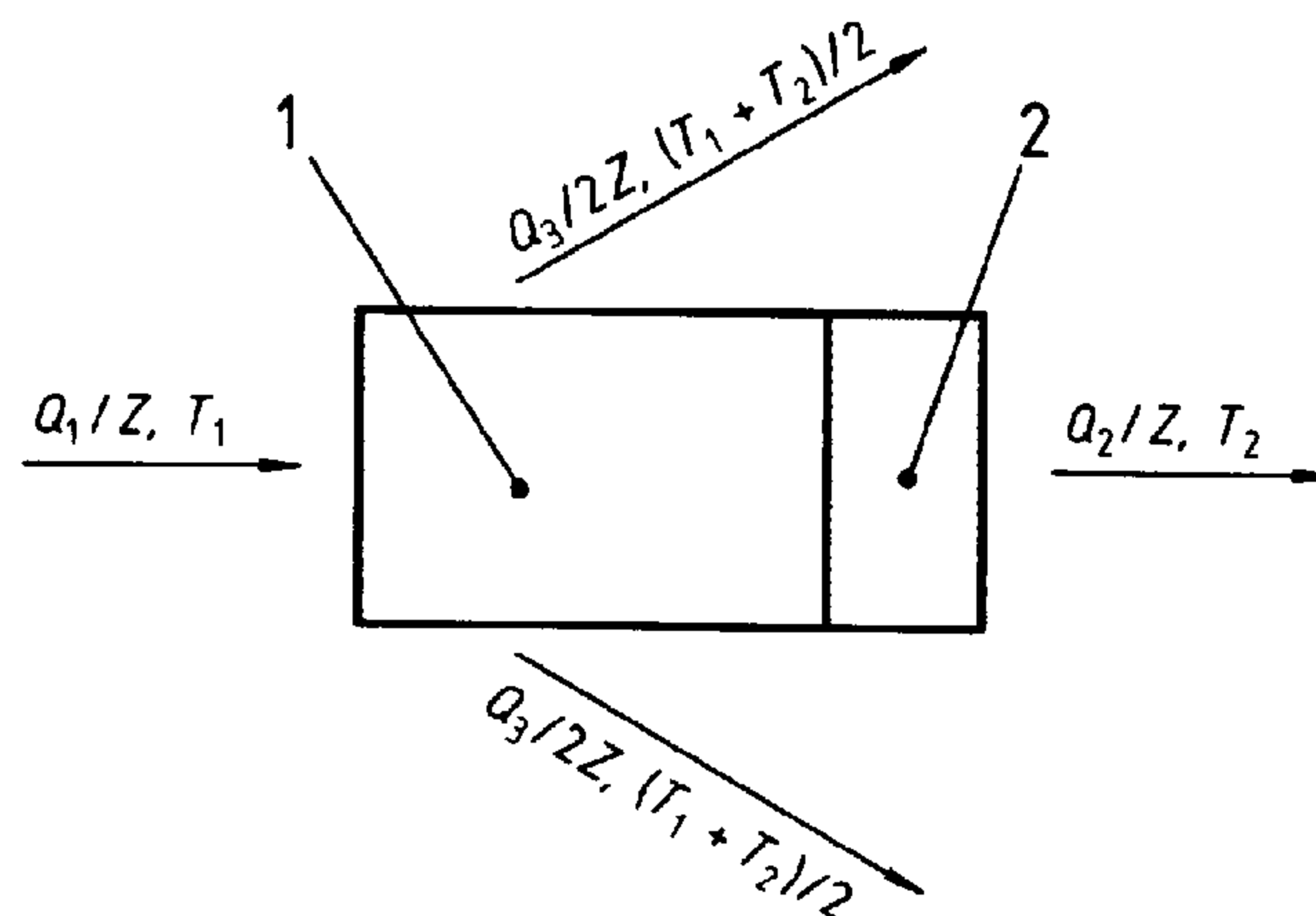

Key

- 1 Wedge surface
- 2 Supporting surface

Figure 3 — Schematic view of the lubricant balance and heat balance of one pad

Due to the rotational motion of the thrust collar, the lubricant is carried, with increasing pressure, in the direction of the converging clearance gap. Thereby part of the lubricant is forced out at the sides of each pad. It is assumed that the lateral portions approximately have the same size.

In Figure 3:

$$Q_1 = Q_2 + Q_3 \quad (8)$$

with

$$Q_1 = Q_1^* \times Q_0 \quad (9)$$

$$Q_3 = Q_3^* \times Q_0 \quad (10)$$

$$Q_2 = Q_1 - Q_3 \quad (11)$$

$$Q_0 = B \times h_{\text{min}} \times U \times Z \quad (12)$$

The relative values of $Q_1^* = Q_1/Q_0$ and $Q_3^* = Q_3/Q_0$ can be taken from ISO 12131-2 as a function of the geometry (B/L and $l_{\text{wed}}/L = 0,75$) and the arising relative lubricant film thickness $h_{\text{min}}/C_{\text{wed}}$. Approximate functions are also given there.

ISO 12131-1:2001(E)

It is assumed that the lubricant forced out at the sides of the pads, Q_3 , has the temperature $(T_1 + T_2)/2$ and the lubricant forced out at the ends, Q_2 , has the temperature T_2 .

5.5 Heat balance

5.5.1 General

The thermal condition of the plain bearing results from the heat balance.

The heat flow $P_{th, f}$ arising from the frictional power P_f in the bearing is dissipated via the bearing housing to the environment and via the lubricant emerging from the bearing. In practical applications, one of the two kinds of heat dissipation is predominant. Additional safety is given to the design by neglecting the other kind of heat dissipation. The following assumptions can be made.

- a) With pressureless lubricated bearings (self-lubrication, natural cooling) heat dissipation to the environment mostly takes place by convection:

$$P_f = P_{th, amb}$$

- b) With pressure-lubricated bearings (recirculating lubrication) heat dissipation mostly takes place via the lubricant (recooling):

$$P_f = P_{th, L}$$

5.5.2 Heat dissipation by convection

Heat dissipation by convection [5.5.1 a)] takes place by thermal conduction and lubricant recirculation in the bearing housing and subsequently by radiation and convection from the surface of the housing to the environment. According to [7] the complex processes during the heat dissipation can be summarized as follows:

$$P_{th, amb} = k_A \times A \times (T_B - T_{amb}) \quad (13)$$

with

$$k_A = 15 \text{ W}/(\text{m}^2 \cdot \text{K}) \text{ to } 20 \text{ W}/(\text{m}^2 \cdot \text{K})$$

or when the bearing housing is subjected to an air-flow at a velocity of $w_{amb} > 1,2 \text{ m/s}$

$$k_A = 7 + 12 \sqrt{w_{amb}} \quad (14)$$

where w_{amb} is expressed in m/s and k_A in $\text{W}/(\text{m}^2 \cdot \text{K})$.

NOTE Thereby, the factor k_A accounts for the thermal conduction in the bearing housing as well as for the convection and radiation from the bearing housing to the environment. That part of the frictional heat arising in the bearing, which is dissipated via the shaft, is neglected here due to its very small amount in most cases.

By equating P_f from equation (7) and $P_{th, amb}$ from equation (13) and with

$$k = \frac{k_A \times A}{B \times L \times Z} \quad (15)$$

the effective bearing temperature is obtained as follows

$$T_{\text{eff}} = f_B \times \frac{U^2 \times \eta_{\text{eff}}}{k \times C_{\text{wed}}} + T_{\text{amb}} \quad (16)$$

In this case, the bearing temperature is

$$T_B = T_{\text{eff}} \quad (17)$$

If the heat-emitting surface A of the bearing housing is not known exactly, the following can be substituted as an approximation:

for cylindrical housings

$$A = 2 \times \frac{\pi}{4} \times D_H^2 + \pi D_H B_H \quad (18)$$

for bearings in the machine structure

$$A = (15 \text{ to } 20) \times B \times L \times Z \quad (19)$$

where

B_H is the axial housing width, in metres;

D_H is the housing outside diameter, in metres.

5.5.3 Heat dissipation by recirculating lubrication

In case of recirculating lubrication, heat dissipation takes place via the lubricant [5.5.1 b)].

$$P_{\text{th, L}} = \rho \times c_p \times Q(T_{\text{ex}} - T_{\text{en}}) \quad (20)$$

For mineral lubricants, the volume specific heat capacity amounts to

$$\rho \times c_p = 1,8 \times 10^6 \text{ J}/(\text{m}^3 \cdot \text{K})$$

Mixing processes in the lubrication recess.

Since a thrust pad bearing consists of a certain number of separate pads it is necessary to consider not only the lubricant flow rate of one single pad but also the lubricant flow rate of the complete bearing and thus the mutual influence of the lubricant flow rate. The lubricant forced out at the end of the pads Q_2 (according to Figure 3) is mixed with newly fed lubricant in the following oil recess, i.e. the lubricant temperature T_1 at the inlet of the lubrication clearance gap is higher by ΔT_1 than that of the newly fed lubricant with temperature T_{en} (see Figure 4).

When determining the temperature difference

$$\Delta T_1 = T_1 - T_{\text{en}} \quad (21)$$

an empirical factor shall be introduced because a purely theoretical consideration of this mixing problem has not yet led to satisfying results.

ISO 12131-1:2001(E)

A mixing factor M can be introduced as follows in order to achieve conformity with the experience gathered up to now (see [5]):

$$\Delta T_1 = \frac{Q_2}{M \times Q + (1 - M) \times Q_3} \times \Delta T_2 = \frac{Q_2^*}{M \times Q^* + (1 - M) \times Q_3^*} \times \Delta T_2 \tag{22}$$

for $Q \geq Q_3$ and $Q^* \geq Q_3^*$ respectively.

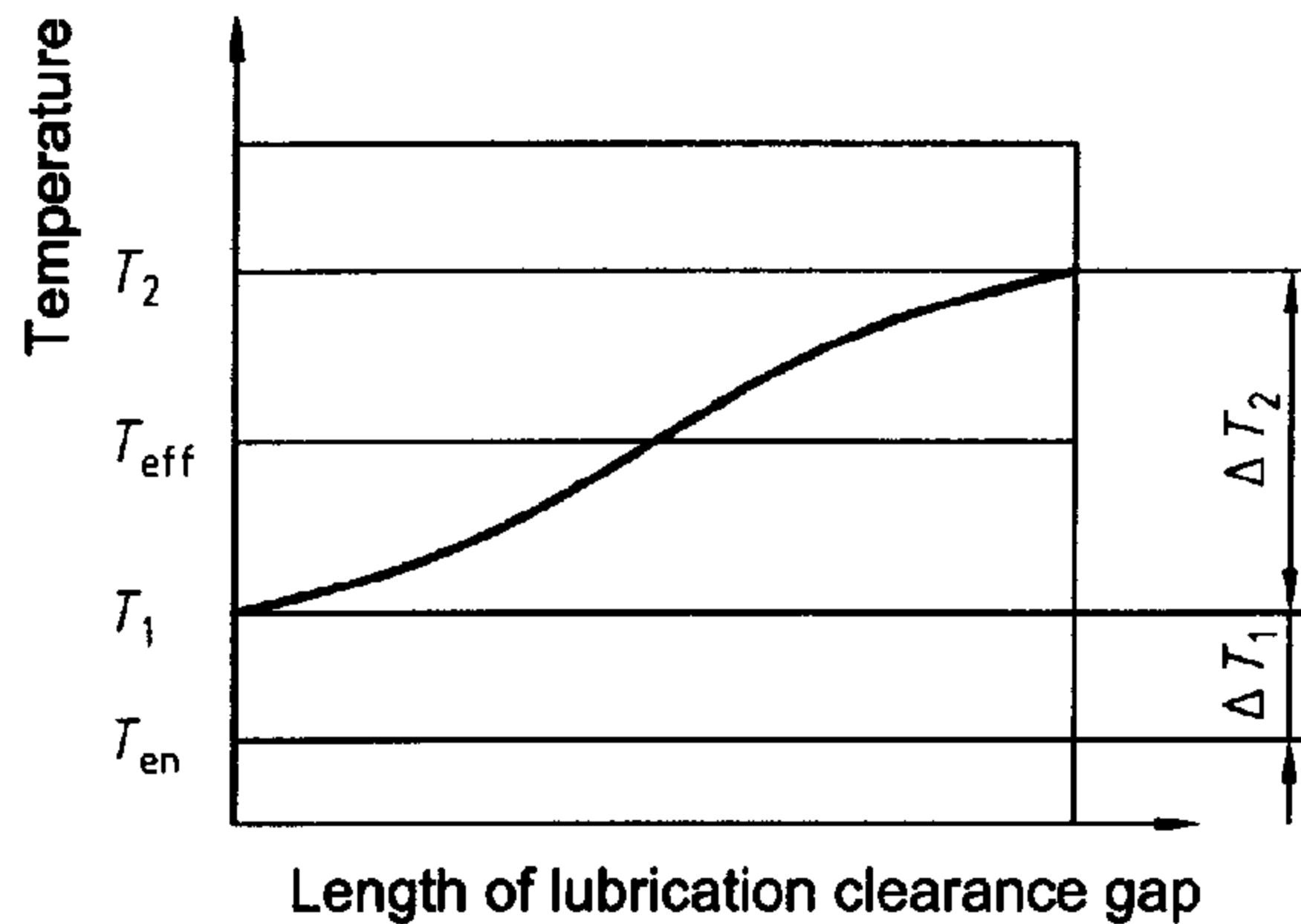

Figure 4 — Graphical representation of the temperature distribution in the lubricant film

To explain the mixing factor we shall examine at the limiting values. A mixing factor $M = 0$ means that there is no mixing in the lubrication recesses, i.e. the lubricant flow rate Q_2 forced out of the lubrication clearance gaps completely enters the following lubrication clearance gap. With this assumption a high lubricant flow rate Q would be ineffective as the largest part of this newly fed lubricant would flow out of the lubrication recesses in a radial direction without influencing the operational parameters. A mixing factor $M = 1$ means "complete" mixing in the lubrication processes. $0,4 \leq M \leq 0,6$ can be introduced as an empirical value. It is a function of the design and cannot be definitely indicated.

The total amount of lubricant to be fed to the thrust bearing can be determined from a given amount of heating

$$\Delta T = T_{ex} - T_{en} \tag{23}$$

$$Q = \frac{P_f}{c_p \times \rho \times \Delta T} = Q^* \times Q_0 \tag{24}$$

By experience the value for ΔT is chosen in the range of 10 K to 30 K.

With

$$\Delta T_2 = T_2 - T_1 \tag{25}$$

it can be written:

$$P_{th, L} = c_p \times \rho \times (Q_2 + 0,5 \times Q_3) \times \Delta T_2 \tag{26}$$

The following relationship is the product of equations (24) and (26) for the temperature rise in the lubrication clearance gap:

$$\Delta T_2 = \frac{\Delta T \times Q^*}{Q_2 + 0,5 \times Q_3} = \frac{\Delta T \times Q^*}{Q_1 - 0,5 \times Q_3} \tag{27}$$

with $\Delta T^* = \frac{\Delta T_1}{\Delta T_2}$ the effective bearing temperature can be determined as follows:

$$T_{\text{eff}} = T_{\text{en}} + \Delta T_1 + 0,5 \times \Delta T_2 = T_{\text{en}} + (\Delta T^* + 0,5) \times \Delta T_2 \quad (28)$$

The bearing temperature is in this case

$$T_{\text{B}} = T_2 = T_{\text{en}} + \Delta T_1 + \Delta T_2 = T_{\text{en}} + (\Delta T^* + 1) \times \Delta T_2 \quad (29)$$

The permissibility of the values calculated for T_{B} and T_2 in accordance with 5.5.1 and 5.5.2 shall be checked by comparison with the guide values T_{lim} in accordance with ISO 12131-3.

5.6 Minimum lubricant film thickness and specific bearing load

After calculation of the thermal steady-state condition, the minimum lubricant film thickness h_{min} can be calculated using the characteristic value of load carrying capacity F_{B}^* .

The permissibility of this value for h_{min} shall be checked by comparison with the guide value h_{lim} in accordance with ISO 12131-3.

The permissibility of the specific bearing load

$$\bar{p} = \frac{F}{B \times L \times Z} \quad (30)$$

shall be checked by comparison with the guide values \bar{p}_{lim} in accordance with ISO 12131-3.

5.7 Operating conditions

If the plain bearing is to be operated under several varying operating conditions over a longer period of time, then those operating conditions under which \bar{p} , h_{min} and T_{B} are most unfavourable shall be checked. First it shall be decided whether the bearing can be lubricated without pressure and whether heat dissipation by convection only is sufficient. For this purpose, the most unfavourable thermal case has to be investigated which, as a rule, corresponds to an operating condition at high rotational frequency and simultaneous high load. If, at pure convection, excessive bearing temperatures arise which even by increasing the dimensions of the bearing or of the surface area of the housing within the given range cannot be lowered to permissible values, then recirculating lubrication and oil recooling are necessary.

If an operating condition with high thermal loading (low dynamic lubricant viscosity) is followed directly by one with high specific bearing load and low rotational frequency, then this new operating condition should be investigated while maintaining the thermal condition of the preceding operating point.

The transition into mixed lubrication takes place when the roughness peaks of thrust collar and bearing are in contact according to the criterion for $h_{\text{lim, tr}}$ in ISO 12131-3, and when possible deformation has not been taken into account.

5.8 Further influence factors

The dynamic viscosity is strongly dependent on temperature. It is thus necessary to know the temperature dependence of the lubricant and its specification. See ISO 3448.

The effective dynamic viscosity η_{eff} is determined at the effective lubricant film temperature T_{eff} ; i.e., η_{eff} results from averaging the temperatures T_1 and T_2 and not from averaging the dynamic viscosities $\eta(T_1)$ and $\eta(T_2)$.

ISO 12131-1:2001(E)

The dynamic viscosity is also pressure-dependent but to a smaller degree. For bearings under steady-state conditions and the usual specific bearing loads \bar{p} , the pressure dependence can, however, be neglected. This neglect represents an additional factor of safety for the design.

In case of non-Newtonian lubricants (intrinsically viscous oils, multi-range oils), reversible and irreversible fluctuations of viscosity occur as a function of the shearing stress in the lubrication clearance gap and of the service life. In [8], these effects are investigated for a few lubricants only and are not considered in this part of ISO 12131.

Annex A (normative)

Examples of calculation

A.1 Example

To be checked is a thrust pad bearing for axial fans with the dimensions $D_i = 0,28$ m, $D_o = 0,34$ m and $B = 0,03$ m which is operated under a load $F = 20\,000$ N at a rotational frequency of 10 s^{-1} .

It is assumed that this operating condition is the critical condition for the heat balance.

The bearing housing surface area, $A = 1,25\text{ m}^2$.

The oil is supplied via the inside diameter D_i . The lubricant used shall be an oil ISO VG 68. It shall be checked whether heat dissipation by convection only is sufficient.

The ambient temperature shall be $T_{\text{amb}} = 20\text{ °C}$, the maximum permissible bearing temperature $T_{\text{lim}} = 90\text{ °C}$.

If T_{lim} is exceeded, recirculating lubrication with external recooling of oil shall be provided. It is assumed in this case that the lubricant is fed to the bearing with an oil inlet temperature $T_{\text{en}} = 40\text{ °C}$.

Dimensions and operational data

Bearing force at nominal rotational frequency:	$F = 20\,000\text{ N}$
Bearing force under stationary conditions:	$F_{\text{st}} = 0$
Thrust collar rotational frequency:	$N = 10\text{ s}^{-1}$
Outside diameter of thrust bearing ring:	$D_o = 340 \times 10^{-3}\text{ m}$
Inside diameter of thrust bearing ring:	$D_i = 280 \times 10^{-3}\text{ m}$
Length of one pad:	$L = 30 \times 10^{-3}\text{ m}$
Length of one wedge:	$l_{\text{wed}} = 22,5 \times 10^{-3}\text{ m}$
Wedge depth:	$C_{\text{wed}} = 0,05 \times 10^{-3}\text{ m}$
Number of pads:	$Z = 24$
Heat-emitting surface of the bearing housing:	$A = 1,25\text{ m}^2$
Heat transfer coefficient:	$k_A = 20\text{ W}/(\text{m}^2 \cdot \text{K})$
Ambient temperature:	$T_{\text{amb}} = 20\text{ °C}$
Lubricant inlet temperature with recirculating lubrication:	$T_{\text{en}} = 40\text{ °C}$

ISO 12131-1:2001(E)

Lubricant outlet temperature with recirculating lubrication:

$T_{\text{ex}} = 50 \text{ }^{\circ}\text{C}$

Limiting values according to ISO 12131-3:

Maximum permissible specific bearing load:

$\bar{p}_{\text{lim}} = 5 \times 10^6 \text{ Pa}$

Maximum permissible bearing temperature:

$T_{\text{lim}} = 90 \text{ }^{\circ}\text{C}$

Minimum permissible lubricant film thickness:

$h_{\text{lim}} = 20 \times 10^{-6} \text{ m}$

Lubricant:

oil ISO VG 68

Density of the lubricant:

$\rho = 900 \text{ kg/m}^3$

Volume specific heat capacity of the lubricant:

$c_p \times \rho = 1,8 \times 10^6 \text{ J/(m}^3\cdot\text{K)}$

Critical Reynolds' number:

$Re_{\text{cr}} = 600$

Table A.1

T_{eff} °C	$\eta_{\text{eff}} (T_{\text{eff}})$ Pa·s
40	0,061
50	0,038
60	0,025
70	0,017
80	0,013
90	0,009 5

Preliminary assumptions

Bearing temperature:

$T_{\text{B},0} = 80 \text{ }^{\circ}\text{C}$

Effective lubricant film temperature:

$T_{\text{eff},0} = 80 \text{ }^{\circ}\text{C}$

Relative minimum lubricant film thickness:

$h_{\text{min}}/C_{\text{wed}} = 0,8$

Calculation by means of the flow chart in accordance with Figure 2The sliding diameter (mean diameter of the bearing ring) D and the pad width B are calculated as follows:

$$D = \frac{D_o + D_i}{2} = 310 \times 10^{-3} \text{ m}$$

$$B = \frac{D_o - D_i}{2} = 30 \times 10^{-3} \text{ m}$$

with $C_{\text{wed}} = 0,05 \times 10^{-3} \text{ m}$ it follows that $h_{\text{min}} = 40 \times 10^{-6} \text{ m}$ and $U = \pi \times D \times N = \pi \times 310 \times 10^{-3} = 9,74 \text{ m/s}$.

Check for permissible specific bearing load in accordance with equation (30):

$$\bar{p} = \frac{20\,000}{30 \times 10^{-3} \times 30 \times 10^{-3} \times 24} = 0,93 \times 10^6 \text{ Pa}$$

The specific bearing load is permissible as

$$\bar{p} = 0,93 \times 10^6 \text{ Pa} < 5 \times 10^6 \text{ Pa (see ISO 12131-3).$$

Heat dissipation by convection

First step:

Assumed bearing temperature $T_{B,0} = T_{\text{eff}} = 80 \text{ }^\circ\text{C}$.

Effective dynamic viscosity of the lubricant at $T_{\text{eff}} = 80 \text{ }^\circ\text{C}$ from the input data:

$$\eta_{\text{eff}} = 0,013 \text{ Pa}\cdot\text{s}$$

Characteristic value of load carrying capacity for pad thrust bearing F_B^* in accordance with equation (4):

$$F_B^* = \frac{20\,000 \times 0,05^2 \times 10^{-6}}{9,74 \times 0,013 \times 30^2 \times 10^{-6} \times 30 \times 10^{-3} \times 24} = 0,609$$

In accordance with Figure 1 in ISO 12131-2:2001, we find for $F_B^* = 0,609$, the value $h_{\text{min}}/C_{\text{wed}} = 0,369$ and thus $h_{\text{min}} = 0,369 \times 0,05 \times 10^{-3} = 18,4 \times 10^{-6} \text{ m}$.

In accordance with Figure 2 in ISO 12131-2:2001, we find for $h_{\text{min}}/C_{\text{wed}} = 0,369$ the value $f_B^* = 2$.

To check the assumed bearing temperature $T_{B,0}$, $T_{B,1}$ is determined in accordance with equation (16) using equation (15):

$$k = \frac{20 \times 1,25}{30 \times 10^{-3} \times 30 \times 10^{-3} \times 24} = 1\,157,4 \text{ W}/(\text{m}^2\cdot\text{K})$$

$$T_{B,1} = \frac{2,0 \times 9,74^2 \times 0,013}{1\,157,4 \times 0,05 \times 10^{-3}} + 20 = 62,6 \text{ }^\circ\text{C}.$$

As $T_{B,1} < T_{B,0}$ and the difference between $T_{B,0}$ and $T_{B,1}$ is not yet sufficiently small (e.g. it can be required that: $|T_{B,0} - T_{B,1}| \leq 2 \text{ K}$), the assumed bearing temperature $T_{B,0} = 80 \text{ }^\circ\text{C}$ shall be corrected.

Second step:

Improved assumption of the bearing temperature:

$$T_{B,0} = 0,5 \times (80 + 62,6) = 71,3 \text{ }^\circ\text{C}$$

$$\eta_{\text{eff}} = 0,0167 \text{ Pa}\cdot\text{s}$$

$$F_B^* = \frac{20\,000 \times 0,05^2 \times 10^{-6}}{9,74 \times 0,0167 \times 30^2 \times 10^{-6} \times 30 \times 10^{-3} \times 24} = 0,474$$

ISO 12131-1:2001(E)

$h_{\min}/C_{\text{wed}} = 0,415$ in accordance with Figure 1 in ISO 12131-2:2001 and thus $h_{\min} = 20,8 \times 10^{-6}$ m.

$f_B^* = 1,79$ according to Figure 2 in ISO 12131-2:2001.

$$T_{B,1} = \frac{1,79 \times 9,74^2 \times 0,0167}{1157,4 \times 0,05 \times 10^{-3}} + 20 = 69,0 \text{ } ^\circ\text{C}$$

As the difference between $T_{B,0}$ and $T_{B,1}$ is not yet sufficiently small, the assumed bearing temperature shall be corrected again.

Third step:

Improved assumption of the bearing temperature:

$$T_{B,0} = 70,2 \text{ } ^\circ\text{C}$$

$$\eta_{\text{eff}} = 0,0173 \text{ Pa}\cdot\text{s}$$

$$F_B^* = \frac{20\,000 \times 0,05^2 \times 10^{-6}}{9,74 \times 0,0173 \times 30^2 \times 10^{-6} \times 30 \times 10^{-3} \times 24} = 0,458$$

$h_{\min}/C_{\text{wed}} = 0,426$ in accordance with Figure 1 in ISO 12131-2:2001 and thus $h_{\min} = 21,3 \times 10^{-6}$ m.

$f_B^* = 1,73$ in accordance with Figure 2 in ISO 12131-2:2001

$$T_{B,1} = \frac{1,73 \times 9,74^2 \times 0,0173}{1157,4 \times 0,05 \times 10^{-3}} + 20 = 69,1 \text{ } ^\circ\text{C}$$

In the third step, the difference between the assumed effective bearing temperature $T_{B,0}$ and the effective bearing temperature $T_{B,1}$ is less than 2 K.

The effective bearing temperature $T_{B,1}$ has thus now been calculated with sufficient accuracy.

As in this case the effective bearing temperature in accordance with equation (17) is equal to the bearing temperature, it is compared with the limiting value T_{lim} :

$$T_{B,1} = T_{\text{eff}} < T_{\text{lim}}$$

As $T_{B,1} < T_{\text{lim}}$, the bearing temperature is permissible.

As $h_{\min} > h_{\text{lim}}$, the minimum lubricant film thickness is permissible.

Check for laminar flow in accordance with equation (2) with the effective viscosity and the determined minimum lubricant film thickness h_{\min} :

$$Re = \frac{900 \times 9,74 \times 21,3 \times 10^{-6}}{0,0173} = 10,8$$

$$Re = 10,8 < Re_{\text{cr}} = 600$$

For the calculated condition, the flow is laminar. That means that this part of ISO 12131 is applicable to this case. The frictional power results from equation (7):

$$P_f = 1,73 \times \frac{9,74^2 \times 0,0173 \times 30 \times 10^{-3} \times 30 \times 10^{-3} \times 24}{0,05 \times 10^{-3}} = 1,23 \times 10^3 \text{ W}$$

A.2 Example

To be checked is a thrust pad bearing for axial fans with the dimensions $D_i = 0,28 \text{ m}$, $D_o = 0,34 \text{ m}$ and $B = 0,03 \text{ m}$ which is operated under a load $F = 40\,000 \text{ N}$ at a rotational frequency of $16,67 \text{ s}^{-1}$.

It is assumed that this operating condition is the critical condition for the heat balance.

The bearing housing surface area, $A = 1,25 \text{ m}^2$.

The oil is supplied via the inside diameter D_i . The lubricant used shall be an oil ISO VG 46. It shall be checked whether heat dissipation by convection only is sufficient.

The ambient temperature shall be $T_{\text{amb}} = 20 \text{ °C}$, the maximum permissible bearing temperature $T_{\text{lim}} = 90 \text{ °C}$.

If T_{lim} is exceeded, recirculating lubrication with external recooling of oil shall be provided. In this case it is assumed that the lubricant is fed to the bearing with an oil inlet temperature $T_{\text{en}} = 40 \text{ °C}$.

Dimensions and operating data

Bearing force at nominal rotational frequency:	$F = 40\,000 \text{ N}$
Bearing force under stationary conditions:	$F_{\text{st}} = 0$
Thrust collar rotational frequency:	$N = 16,67 \text{ s}^{-1}$
Outside diameter of thrust bearing ring:	$D_o = 340 \times 10^{-3} \text{ m}$
Inside diameter of thrust bearing ring:	$D_i = 280 \times 10^{-3} \text{ m}$
Length of one pad:	$L = 30 \times 10^{-3} \text{ m}$
Length of one wedge surface:	$l_{\text{wed}} = 22,5 \times 10^{-3} \text{ m}$
Wedge depth:	$C_{\text{wed}} = 0,055 \times 10^{-3} \text{ m}$
Number of pads:	$Z = 24$
Heat-emitting surface of the bearing housing:	$A = 1,25 \text{ m}^2$
Heat transfer coefficient:	$k = 20 \text{ W}/(\text{m}^2 \cdot \text{K})$
Ambient temperature:	$T_{\text{amb}} = 20 \text{ °C}$
Lubricant inlet temperature with recirculating lubrication:	$T_{\text{en}} = 40 \text{ °C}$
Lubricant outlet temperature with recirculating lubrication:	$T_{\text{ex}} = 50 \text{ °C}$

ISO 12131-1:2001(E)

Limiting values in accordance with ISO 12131-3

Maximum permissible specific bearing load:	$\bar{p}_{lim} = 5 \times 10^6 \text{ Pa}$
Maximum permissible bearing temperature:	$T_{lim} = 90 \text{ °C}$
Minimum permissible lubricant film thickness:	$h_{lim} = 20 \times 10^{-6} \text{ m}$
Lubricant:	oil ISO VG 46
Density of the lubricant:	$\rho = 900 \text{ kg/m}^3$
Volume specific heat capacity of the lubricant:	$c_p \times \rho = 1,8 \times 10^6 \text{ J/(m}^3\cdot\text{K)}$
Critical Reynolds' number:	$Re_{cr} = 600$

Table A.2

T_{eff} °C	$\eta_{eff}(T_{eff})$ Pa·s
40	0,041
50	0,027
60	0,018
70	0,013
80	0,009 5
90	0,007 3
100	0,005 7

Preliminary assumptions

Bearing temperature:	$T_{B,0} = 80 \text{ °C}$
Effective lubricant film temperature:	$T_{eff,0} = 80 \text{ °C}$
Relative minimum lubricant film thickness:	$h_{min}/C_{wed} = 0,8$

Calculation by means of the flow chart in accordance with Figure 2The sliding diameter D and the pad width B are calculated as follows:

$$D = \frac{D_o + D_i}{2} = 310 \times 10^{-3} \text{ m}$$

$$B = \frac{D_o - D_i}{2} = 30 \times 10^{-3} \text{ m}$$

with $C_{wed} = 0,055 \times 10^{-3} \text{ m}$ it follows $h_{min} = 44 \times 10^{-6} \text{ m}$ and

$$U = \pi \times D \times N = \pi \times 310 \times 10^{-3} = 16,23 \text{ m/s.}$$

Check for permissible specific bearing load according to equation (30):

$$\bar{p} = \frac{40000}{30 \times 10^{-3} \times 30 \times 10^{-3} \times 24} = 1,85 \times 10^6 \text{ Pa}$$

The specific bearing load is permissible, as

$$\bar{p} = 1,85 \times 10^6 \text{ Pa} < 5 \times 10^6 \text{ Pa (see ISO 12131-3).$$

Heat dissipation by convection

First step:

Assumed bearing temperature $T_{B,0} = T_{\text{eff}} = 80 \text{ }^\circ\text{C}$.

Effective dynamic viscosity of the lubricant at $T_{\text{eff}} = 80 \text{ }^\circ\text{C}$ from the input data:

$$\eta_{\text{eff}} = 0,0095 \text{ Pa}\cdot\text{s}$$

Characteristic value of load carrying capacity for thrust pad bearing F_B^* in accordance with equation (4):

$$F_B^* = \frac{40000 \times (0,055 \times 10^{-3})^2}{16,23 \times 0,0095 \times (30 \times 10^{-3})^2 \times 30 \times 10^{-3} \times 24} = 1,21$$

In accordance with Figure 1 in ISO 12131-2:2001, we find for $F_B^* = 1,21$ the value $h_{\text{min}}/C_{\text{wed}} = 0,23$ and thus $h_{\text{min}} = 0,23 \times 0,055 \times 10^{-3} = 12,6 \times 10^{-6} \text{ m}$.

According to Figure 2 in ISO 12131-2:2001, we find for $h_{\text{min}}/C_{\text{wed}} = 0,23$ the value $f_B^* = 2,95$.

To check the assumed bearing temperature $T_{B,0}$, $T_{B,1}$ is determined according to equation (16) using equation (15).

$$k = \frac{20 \times 1,25}{30 \times 10^{-3} \times 30 \times 10^{-3} \times 24} = 1\,157,4 \text{ W}/(\text{m}^2 \cdot \text{K})$$

$$T_{B,1} = \frac{2,95 \times 16,23^2 \times 0,0095}{1\,157,4 \times 0,055 \times 10^{-3}} + 20 = 136 \text{ }^\circ\text{C}$$

As $T_{B,1} > T_{B,0}$ and the difference between $T_{B,0}$ and $T_{B,1}$ is not yet sufficiently small (e.g. it can be required that: $|T_{B,0} - T_{B,1}| \leq 2 \text{ K}$), the assumed bearing temperature $T_{B,0} = 80 \text{ }^\circ\text{C}$ is to be corrected.

Second step:

Improved assumption of the bearing temperature:

$$T_{B,0} = 0,5 \times (80 + 136) = 108 \text{ }^\circ\text{C}$$

$$\eta_{\text{eff}} = 0,0048 \text{ Pa}\cdot\text{s}$$

$$F_B^* = \frac{40000 \times (0,055 \times 10^{-3})^2}{16,23 \times 0,0048 \times (30 \times 10^{-3})^2 \times 30 \times 10^{-3} \times 24} = 2,4$$

ISO 12131-1:2001(E)

$h_{\min}/C_{\text{wed}} = 0,144$ according to Figure 1 in ISO 12131-2:2001 and thus $h_{\min} = 7,92 \times 10^{-6}$ m.

$f_B^* = 4,29$ according to Figure 2 in ISO 12131-2:2001.

$$T_{B,1} = \frac{4,29 \times 16,23^2 \times 0,0048}{1157,4 \times 0,055 \times 10^{-3}} + 20 = 105,2^\circ\text{C}$$

As the difference between $T_{B,0}$ and $T_{B,1}$ is not yet sufficiently small, the assumed bearing temperature $T_{B,0} = 108^\circ\text{C}$ is to be corrected again.

Third step:

Improved assumption of the bearing temperature:

$$T_{B,0} = 106,6^\circ\text{C}$$

$$\eta_{\text{eff}} = 0,0049 \text{ Pa}\cdot\text{s}$$

$$F_B^* = \frac{40\,000 \times (0,055 \times 10^{-3})^2}{16,23 \times 0,0049 \times (30 \times 10^{-3})^2 \times 30 \times 10^{-3} \times 24} = 2,35$$

$h_{\min}/C_{\text{wed}} = 0,147$ according to Figure 1 in ISO 12131-2:2001 and thus $h_{\min} = 8,08 \times 10^{-6}$ m.

$f_B^* = 4,17$ according to Figure 2 in ISO 12131-2:2001.

$$T_{B,1} = \frac{4,17 \times 16,23^2 \times 0,0049}{1157,4 \times 0,055 \times 10^{-3}} + 20 = 104,6^\circ\text{C}$$

As $|T_{B,0} - T_{B,1}| \leq 2$ K, the bearing temperature has been calculated with sufficient accuracy.

Comparison with the limiting value T_{lim} :

$T_{B,1} > T_{\text{lim}}$, thus the bearing temperature is not permissible. Heat dissipation by convection is therefore not sufficient and the bearing is to be cooled by the lubricant (recirculating lubrication).

Heat dissipation by recirculating lubrication

First step:

Assumed effective bearing temperature $T_{B,0} = T_{\text{eff},0} = 80^\circ\text{C}$. (see "Heat dissipation by convection").

$$\eta_{\text{eff}} = 0,0095 \text{ Pa}\cdot\text{s}$$

$$F_B^* = 1,21$$

$h_{\min}/C_{\text{wed}} = 0,23$ according to Figure 1 in ISO 12131-2:2001 and $h_{\min} = 12,6 \times 10^{-6}$ m.

$f_B^* = 2,95$ according to Figure 2 in ISO 12131-2:2001.

Frictional power P_f in accordance with equation (7):

$$P_f = \frac{2,95 \times 16,23^2 \times 0,0095 \times 30 \times 10^{-3} \times 30 \times 10^{-3} \times 24}{0,055 \times 10^{-3}} = 2,9 \times 10^3 \text{ W}$$

According to equation (12), the relative lubricant flow rate Q_0 is

$$Q_0 = 30 \times 10^{-3} \times 12,6 \times 10^{-6} \times 16,23 \times 24 = 1,47 \times 10^{-4} \text{ m}^3/\text{s}$$

With the assumed lubricant temperature difference in accordance with equation (23) of $\Delta T = 12 \text{ K}$, the relative lubricant flow rate of the bearing Q^* in accordance with equation (24) is:

$$Q^* = \frac{2,90 \times 10^3}{1,8 \times 10^6 \times 12 \times 1,47 \times 10^{-4}} = 0,913$$

According to Figures 3 a) and 3 b) in ISO 12131-2:2001 we find for $h_{\min}/C_{\text{wed}} = 0,23$

$$Q_1^* = 1,55$$

$$Q_3^* = 0,93$$

Temperature rise in the lubrication clearance gap ΔT_2 in accordance with equation (27):

$$\Delta T_2 = \frac{12 \times 0,913}{1,55 - 0,5 \times 0,93} = 10,1 \text{ K}$$

Increase of the lubricant temperature after the mixing process ΔT_1 in accordance with equation (22) with the relative lubricant flow rates in accordance with equations (9), (10), (11) and (24) and with a chosen value for the mixing factor $M = 0,5$:

$$\Delta T_1 = \frac{1,55 - 0,93}{0,5 \times 0,913 + (1 - 0,5) \times 0,93} \times 10,1 = 6,8 \text{ K}$$

To check the assumed bearing temperature, $T_{\text{eff}, 0}$, T_{eff} is determined in accordance with equation (28):

$$T_{\text{eff}, 1} = 40 + 6,8 + 0,5 \times 10,1 = 51,8 \text{ }^\circ\text{C}$$

As $|T_{\text{eff}, 0} - T_{\text{eff}, 1}| \geq 2 \text{ K}$, the assumed bearing temperature $T_{\text{eff}, 0} = 80 \text{ }^\circ\text{C}$ is to be corrected.

Improved assumption of the bearing temperature:

$$T_{\text{eff}, 0} = 0,5 \times (51,8 + 80) = 65,9 \text{ }^\circ\text{C}$$

Further steps of iteration are given in Table A.3

In the fifth calculation step, the difference between the assumed effective bearing temperature $T_{\text{eff}, 0}$ and the effective bearing temperature $T_{\text{eff}, 1}$ is smaller than 2 K, i.e. the effective bearing temperature T_{eff} has therefore been calculated with sufficient accuracy.

The bearing temperature T_B , which is equal to the lubricant outlet temperature T_2 , in accordance with equation (29):

$$T_B = T_2 = 40 + 9,4 + 10,1 = 59,5 \text{ }^\circ\text{C}$$

ISO 12131-1:2001(E)

As $T_2 < T_{lim}$, the lubricant outlet temperature is permissible.

As $h_{min} > h_{lim}$, the minimum lubricant film thickness is permissible.

Check for laminar flow in accordance with equation (2):

$$Re = \frac{900 \times 16,23 \times 21,4 \times 10^{-6}}{0,021} = 14,9$$

$$Re = 14,9 < Re_{cr} = 600$$

For the calculated condition, the flow is laminar. That means that this part of ISO 12131 is applicable to this case.

The lubricant flow rate through the bearing is calculated from equation (24) as follows:

$$Q = 0,765 \times 2,5 \times 10^{-4} = 1,91 \times 10^{-4} \text{ m}^3/\text{s}$$

Table A.3

Variable parameter	Unit	Steps of iteration				
		1	2	3	4	5
$T_{eff,0}$	°C	80	65,9	59,4	57	55,7
η_{eff}	Pa·s	0,009 5	0,015	0,018	0,02	0,021
F_B^*	–	1,21	0,767	0,629	0,575	0,548
h_{min}/C_{wed}	–	0,23	0,32	0,35	0,38	0,39
h_{min}	m	$12,6 \times 10^{-6}$	$17,6 \times 10^{-6}$	$19,2 \times 10^{-6}$	$20,9 \times 10^{-6}$	$21,4 \times 10^{-6}$
f_B^*	–	2,95	2,2	2,08	1,92	1,9
P_f	W	$2,90 \times 10^3$	$3,41 \times 10^3$	$3,94 \times 10^3$	$3,97 \times 10^3$	$4,13 \times 10^3$
Q_0	m ³ /s	$1,47 \times 10^{-4}$	$2,06 \times 10^{-4}$	$2,24 \times 10^{-4}$	$2,44 \times 10^{-4}$	$2,50 \times 10^{-4}$
\dot{Q}	–	0,913	0,766	0,814	0,753	0,765
\dot{Q}_1	–	1,55	1,32	1,24	1,18	1,19
\dot{Q}_3	–	0,93	0,68	0,61	0,56	0,57
ΔT_2	K	10,1	9,4	10,5	10	10,1
ΔT_1	K	6,8	8,3	9,3	9,4	9,4
$T_{eff,1}$	°C	51,8	53	54,6	54,4	54,4
$ T_{eff,1} - T_{eff,0} $	K	28,2	12,9	4,8	2,6	1,3

Bibliography

- [1] REYNOLDS, O., *On the theory of lubrication and its application to Mr. Beauchamp Tower's experiments, including an experimental determination of the viscosity of olive oil*. Phil. Trans. (1966) 177, pp 157 – 234
- [2] KANARACHOS, A., *Ein Beitrag zum Problem hydrodynamischer Gleitlager maximaler Tragfähigkeit (A contribution to the problem concerning hydrodynamic plain bearings of maximum load carrying capacity)*. Konstruktion 28 (1976) pp. 319 – 395
- [3] GLIENICKE, J., LINDLOFF, K. and MEDHIOUB, M., *Axialgleitlager bei hohen Umlaufgeschwindigkeiten und hohen spezifischen Belastungen (Plain thrust bearings at high rotational frequencies and high specific loads)*. Konstruktion 49 (1997), pp. 39 – 47
- [4] WILCOCK and BOOSER, *Bearing Design and Application*. McGraw-Hill Book Company New York (1957)
- [5] POLLMANN, E., *Berechnungsverfahren für Axiallager (Calculation methods for thrust bearings)*. Konstruktion 33 (1981)
- [6] EFFERTZ, J., *Entwicklung eines Finite-Element-Programmsystems für die Analyse von Gleitlagern unter Berücksichtigung thermischer und elastischer Effekte (Development of a finite element programme system for the analysis of plain bearings taking into consideration thermal and elastic effects)*. Dissertation Ruhr-Universität, Bochum (1983)
- [7] VOGELPOHL, G., *Betriebssichere Gleitlager (Operationally reliable plain bearings)*. Springer-Verlag, Berlin-Heidelberg-New York (1967)
- [8] WISSUSSEK, D., *Der Einfluß reversibler und irreversibler Viskositätsänderungen auf das Verhalten hydrodynamischer, stationär belasteter Gleitlager (Influence of reversible and irreversible fluctuations of viscosity on the behaviour of hydrodynamic plain bearings under steady-state conditions)*. Dissertation Technische Universität, Hannover (1975)

ISO 12131-1:2001(E)

ICS 21.100.10

Price based on 25 pages